

TECHNICAL DATA

CABLE GLAND TYPE : TMC2X
 INGRESS PROTECTION : IP66, NEMA 4X
 PROCESS CONTROL SYSTEM : BS EN ISO 9001

HAZARDOUS AREA CLASSIFICATION

ATEX CERTIFICATION No : SIRA 09ATEX1165X
 ATEX CERTIFICATION CODE : II 2 GD Exd IIC Gb / Ex e IIC Gb / Ex ta IIIC Da
 IEC Ex CERTIFICATION No : IEC Ex SIR.09.0069X
 IEC Ex CERTIFICATION CODE : Ex d IIC Gb / Ex e IIC Gb / Ex ta IIIC Da
 CSA-us CERTIFICATION No : CSA.09.2194053X
 CSA-us CERTIFICATION CODE : Class I Div 1, 2 Gp A, B, C, D; Class II, Div 1, 2 Gp E, F, G; Class 1 Zone 1, 2, AEx d IIC, AEx e II; Ex d IIC, Ex e II; SL

INSTALLATION INSTRUCTIONS

Installation should only be performed by a competent person using the correct tools. Read all instructions before beginning installation.

INSTALLATION GUIDANCE NOTES

- In accordance with NEC requirements, connectors with NPT and Metric entry threads are suitable for both Divisions and Zones.
- In accordance with CEC requirements, connectors with NPT threads are suitable for both Divisions and Zones. Connectors with Metric threads are only suitable for Zones unless fitted with an approved Metric to NPT thread conversion adaptor.
- For IEC and/or ATEX installations:
 - All tapes/shields/foils must be removed and any twisted pairs/triples unwound to form individual conductors.
 - Drain Wires: Pass sleeving/heat shrink tube over the drain, making sure it is positioned within the resin Tube/Resin Dam area. If required, shrink the tube by applying heat, then treat the drain wire as a conductor.
- For NEC Class 1 Div 1 and Zone 1 see article 501.15 of the NEC.

SPECIAL CONDITIONS FOR SAFE USE

- The glands shall only be fitted to enclosures where temperatures, at the point of mounting, is below 85°C.
- The cable shall be effectively clamped as close as possible to the gland.
- When used for Ex e or Ex ta applications, the user shall provide a suitable interface seal between the gland and associated enclosure to maintain the level of ingress protection of the enclosure they are fitted to.

Ordering Reference (Std Thread)		Entry Thread NPT	Diameter Over Cores	Min Thread Length	Cable Armor Diameter	Cable Jacket Diameter	Across Flats Range	Across Corners	Assembled Length	Approx Weight Aluminium (ozs)	Gland Size				
Aluminium	NP Brass	S. Steel	Standard	Option	Min	Max	Min	Max							
TMC2X-050A075	TMC2X-050NB075	TMC2X-050SS075	1/2"	-	0.51	0.78	0.42	0.63	0.50	0.75	1.20	1.30	1.65	2.29	20S
TMC2X-075A075	TMC2X-075NB075	TMC2X-075SS075	-	3/4"	0.51	0.80									
TMC2X-075A099	TMC2X-075NB099	TMC2X-075SS099	3/4"	-	0.71	0.80									
TMC2X-050A099	TMC2X-050NB099	TMC2X-050SS099	-	1/2"	0.51	0.78	0.60	0.89	0.69	0.99	1.48	1.60	1.97	3.00	20
TMC2X-100A118	TMC2X-100NB118	TMC2X-100SS118	1"	-	0.94	0.98									
TMC2X-075A118	TMC2X-075NB118	TMC2X-075SS118	-	3/4"	0.71	0.80	0.79	1.10	0.87	1.18	1.81	1.95	2.13	5.11	25
TMC2X-125A137	TMC2X-125NB137	TMC2X-125SS137	1-1/4"	-	1.20	1.00									
TMC2X-100A137	TMC2X-100NB137	TMC2X-100SS137	-	1"	0.94	0.98	0.94	1.28	1.02	1.37	2.05	2.21	2.34	6.70	32
TMC2X-150A162	TMC2X-150NB162	TMC2X-150SS162	1-1/2"	-	1.46	1.03									
TMC2X-125A162	TMC2X-125NB162	TMC2X-125SS162	-	1-1/4"	1.20	1.00	1.22	1.50	1.30	1.62	2.36	2.55	2.44	8.82	40S
TMC2X-150A190	TMC2X-150NB190	TMC2X-150SS190	1-1/2"	-	1.46	1.03									
TMC2X-125A190	TMC2X-125NB190	TMC2X-125SS190	-	1-1/4"	1.20	1.00	1.49	1.72	1.57	1.90	2.56	2.76	2.44	9.45	40
TMC2X-200A200	TMC2X-200NB200	TMC2X-200SS200	2"	-	1.63	1.06									
TMC2X-150A200	TMC2X-150NB200	TMC2X-150SS200	-	1-1/2"	1.46	1.03	1.57	1.88	1.65	2.00	2.75	2.97	2.60	11.06	50S
TMC2X-250A233	TMC2X-250NB233	TMC2X-250SS233	2-1/2"	-	2.13	1.57									
TMC2X-200A233	TMC2X-200NB233	TMC2X-200SS233	-	2"	1.90	1.06	1.79	2.21	1.91	2.33	2.95	3.19	2.64	12.77	63S
TMC2X-300A272	TMC2X-300NB272	TMC2X-300SS272	3"	-	2.55	1.63									
TMC2X-250A272	TMC2X-250NB272	TMC2X-250SS272	-	2-1/2"	2.37	1.57	2.14	2.61	2.27	2.72	3.54	3.82	2.76	24.69	75
TMC2X-350A325	TMC2X-350NB325	TMC2X-350SS325	3-1/2"	-	2.98	1.68									
TMC2X-300A325	TMC2X-300NB325	TMC2X-300SS325	-	3"	2.98	1.63	2.49	2.97	2.62	3.25	4.33	4.68	3.46	42.68	90
TMC2X-400A376	TMC2X-400NB376	TMC2X-400SS376	4"	-	3.49	1.73									
TMC2X-350A376	TMC2X-350NB376	TMC2X-350SS376	-	3-1/2"	3.49	1.68	2.95	3.54	3.16	3.76	4.84	5.23	3.68	53.44	100
TMC2X-400A425	TMC2X-400NB425	TMC2X-400SS425	4"	-	3.49	1.73	3.52	3.94	3.70	4.25	5.23	5.65	3.89	59.19	115

All dimensions in inches

Cable Connector Selection Table

ASSEMBLY FITTING INSTRUCTIONS FOR INSTALLATION OF CMP CABLE CONNECTOR TYPE TMC2X

CMP TYPE TMC2X CABLE CONNECTOR FOR USE WITH INTERLOCKED & CORRUGATED CONTINUOUSLY WELDED METAL CLAD (TYPE MC OR MC-HL) OR TECK ARMORED AND ARMORED & JACKETED CABLES IN ORDINARY, WET & HAZARDOUS LOCATIONS.

INCORPORATING EC DECLARATION OF CONFORMITY TO DIRECTIVE 94/9/EC

CABLE CONNECTOR TYPE TMC2X

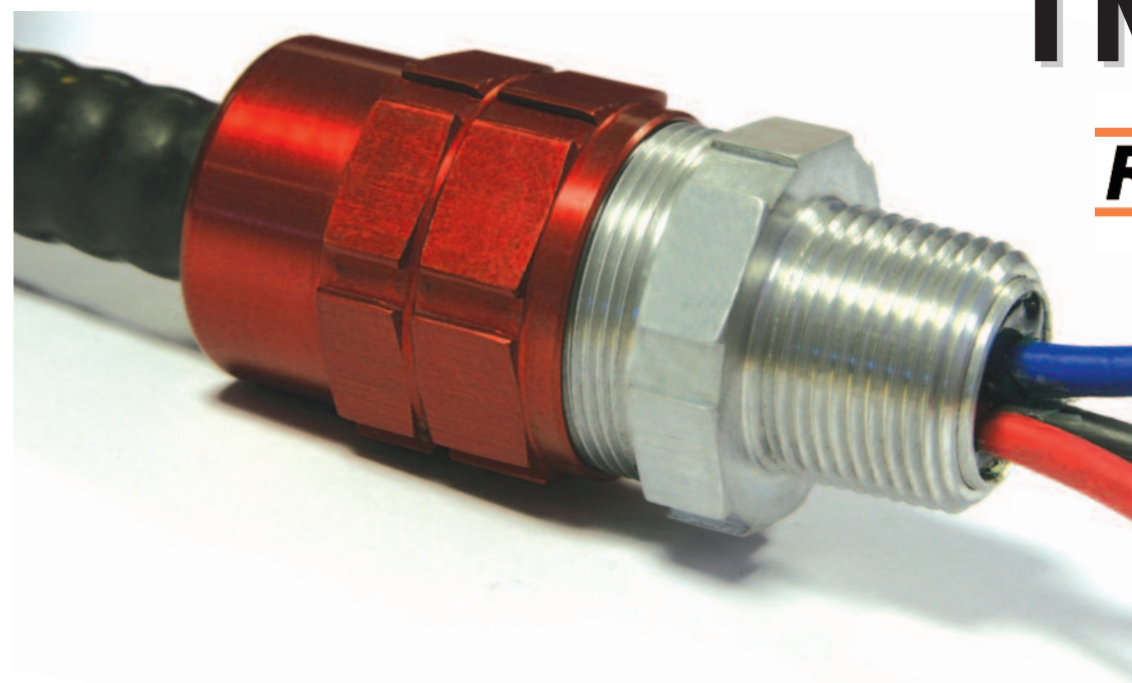

CMP PRODUCTS

I, the undersigned, hereby declare that the equipment referred to herein conforms to 94/9/EC directive.

G. I. Mood

Dr Geof Mood - Technical Director - (Authorised Person)

Registered Office: Glasshouse Street • St. Peters • Newcastle upon Tyne • NE6 1BS
 Tel: +44 191 265 7411 • Fax: +44 191 265 0581
 E-Mail: cmp@cmp-products.co.uk • Web: www.cmp-products.com
 Company Number:



CE 0518

Notified Body: Sira Certification Service, Rake Lane, Chester CH4 9JN, England.

www.cmp-products.com



Logo's shown for illustration purposes only. Please check certification for details

INSTALLATION INSTRUCTIONS FOR TMC2X CABLE CONNECTOR

CABLE CONNECTOR COMPONENTS

1. RapidEx Resin
2. Resin Tube
3. Entry Component
4. Sealant Tape or Inner Jacket
5. Resin Dam
6. Tube Spacer
7. End Stop
8. Armor Spacer
9. Grounding Spring
10. Angled Spacer
11. Jacket Seal
12. Outer Nut

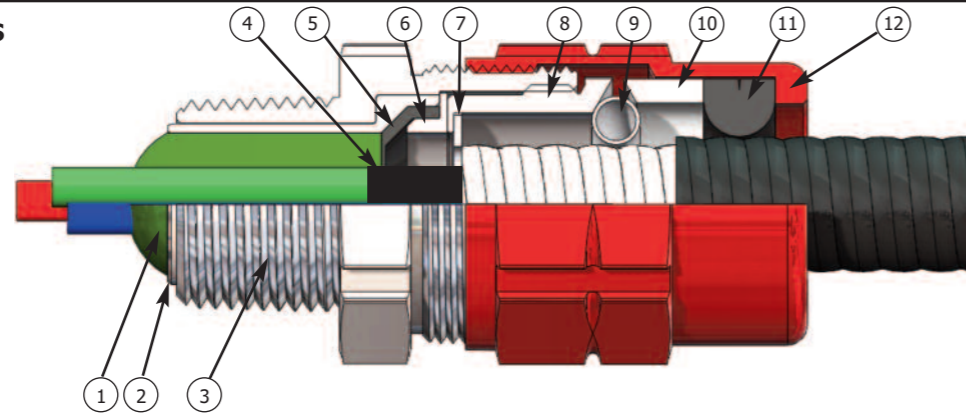

PLEASE READ ALL INSTRUCTIONS CAREFULLY BEFORE BEGINNING THE INSTALLATION

1. Cable preparation — Without Inner Jacket

Strip back the jacket armor to suit the equipment geometry.

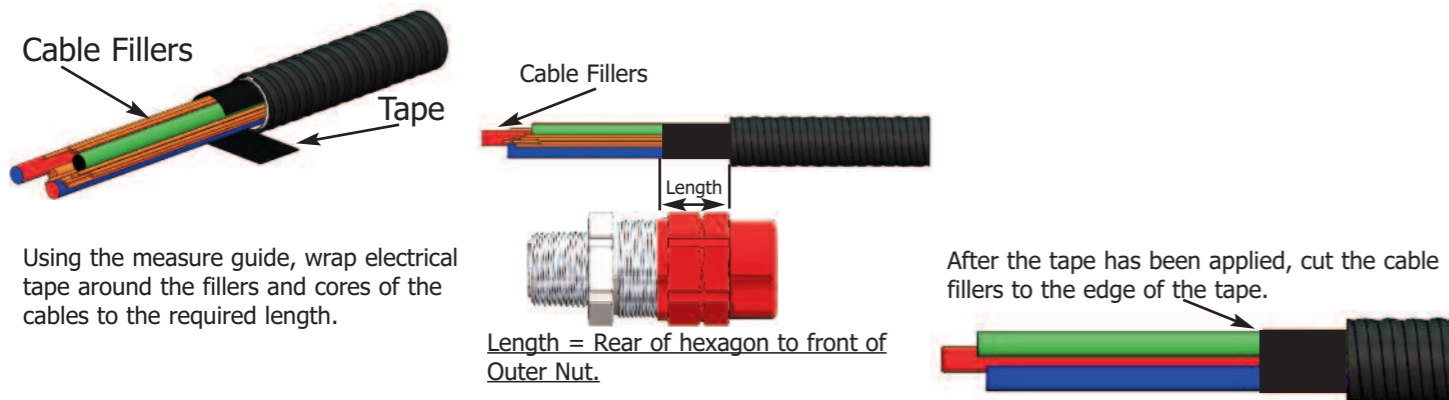

1. Cable preparation — With Inner Jacket

Strip back the jacket armor to suit the equipment geometry.

Using the measure guide, cut the cable inner jacket (and any cable fillers) to the required length. If inner jacket is too large for the Resin Dam, cut off and replace with electrical tape.

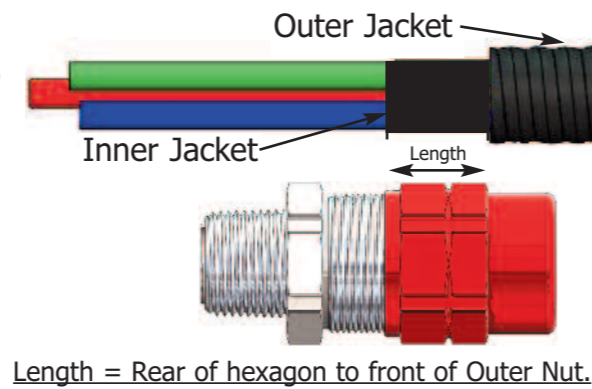

2. Using the armor measure guide, expose the armor further by stripping the cable jacket to distance "L".

NOTE: When the outer jacket is at its maximum, distance "L" may have to be increased by up to 10%.

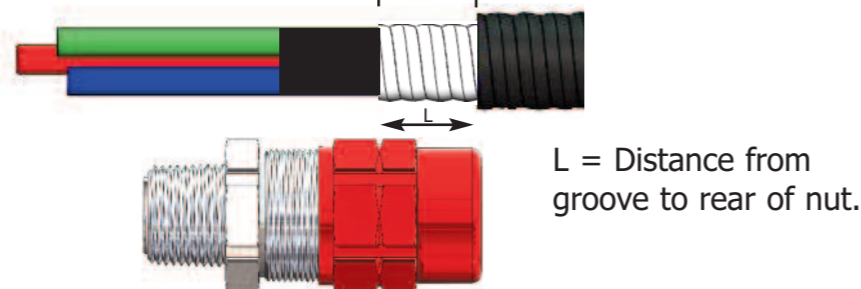

3. Electrical tape MUST be wrapped around the tips of the cable cores.

This is to ensure the cable cores are together and also to cover any sharp edges that could potentially tear the Resin Dam during installation.



4. Pass the cable through the connector until the armor makes contact with the end stop. If it is not possible for the insulated conductors to pass through the end stop then it should be removed so that the armor can make contact with the integral end stop within the entry component. **At this stage unscrew the Outer Nut and slide it back over the cable, enough to have access to the Armor Spacer. If no access is gained repeat step 2 and trim the outer jacket up to "L" plus 10%.** Assemble the connector.

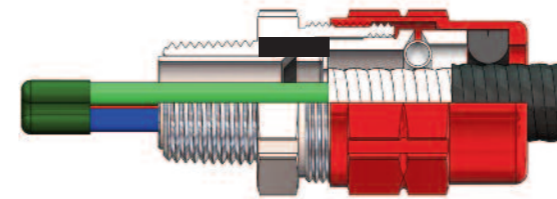

Hand tighten the Outer Nut to compress the Grounding Spring to secure the armor. Do not over tighten the Outer Nut. Remove electrical tape from cable core tips. Separate the cable cores slightly to allow resin to flow between them. When insulating grounding conductors are present, spread the strands slightly to allow the resin to form a full seal. **Refer to 'RapidEx' assembly instructions to fill the connector resin tube with the required amount of RapidEx.**

Note: For instrumentation cables utilizing shielded cable, individual/overall drain wires, see *Installation Guidance Notes* overleaf.

5. Once the resin has cured, loosen the Outer Nut to ensure that the Grounding Spring is not gripping the cable. Slide the Outer Nut back over the cable, enough to loosen the Armor Spacer from the Entry Component. Screw the Entry Component into the enclosure. Retighten the Armor Spacer when the entry component is fully tightened into the enclosure.

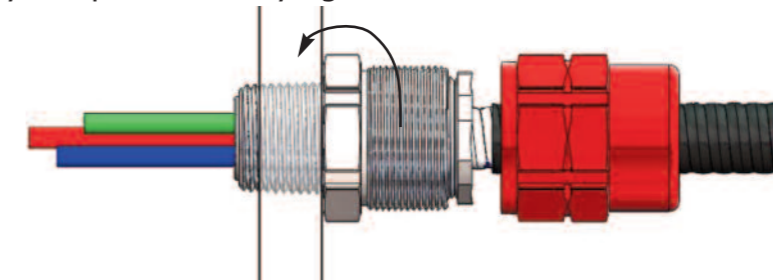

6. Finally, holding the cable central in the gland, tighten the Outer Nut to compress the Grounding Spring to secure the armor and the seal to engage the cable jacket. Do not over tighten the Outer Nut. The Entry Component and Outer Nut do not have to close face to face.

