

TECHNICAL DATA

CABLE GLAND TYPE : A2FRC
 INGRESS PROTECTION : IP66, NEMA 4X
 PROCESS CONTROL SYSTEM : BS EN ISO 9001

HAZARDOUS AREA CLASSIFICATION

ATEX CERTIFICATION No : SIRA06ATEX1097X, SIRA07ATEX4326X
 ATEX CERTIFICATION CODE :  II 2 GD Ex d IIC, Ex e II, Ex nR II, Ex tD A21 IP66
 IEC Ex CERTIFICATION No : IEC Ex SIR.06.0040X
 IEC Ex CERTIFICATION CODE : Ex d IIC / Ex e II / Ex nR II, Ex tD A21 IP66
 CSA CERTIFICATION No : 1211841
 CSA CERTIFICATION CODE : Ex d IIC & Ex e II, CSA Enclosure Type 4X

INSTALLATION INSTRUCTIONS

Installation should only be performed by a competent person using the correct tools. Read all instructions before beginning installation.

SPECIAL CONDITIONS FOR SAFE USE

1. The A2FRC shall only be used where the temperature, at the point of entry, is between -60°C and +130°C.
2. The entry component threads may need additional sealing to maintain the ingress protection rating as applicable to the associated equipment to which it will be attached.
3. If used to connect to flexible conduit, the conduit must be clamped to prevent pulling or twisting of the cable.

ACCESSORIES

The following accessories are available from CMP Products, as optional extras, to assist with fixing, sealing and earthing :-
 Locknut | Earth Tag | Serrated Washer | Entry Thread (I.P.) Sealing Washer | Shroud*

Cable Gland Size	Entry Threads			Min Thread Length	Standard Female Connection Thread	Overall Cable Diameter		Across Flats Max	Across Corners Max	Nominal Protrusion Length	Ordering Reference (Brass Metric Male x NPT Female)	Cable Gland Weight (Kgs)
	Standard Metric	NPT	Option NPT			Min	Max					
20S/16	M20	1/2"	3/4"	15.0	1/2"	3.2	8.7	24.0	25.9	37.0	20S16A2FRC1RA031	0.054
20S	M20	1/2"	3/4"	15.0	1/2"	6.1	11.7	24.0	25.9	37.0	20SA2FRC1RA031	0.054
20	M20	1/2"	3/4"	15.0	1/2"	6.5	14.0	27.0	29.2	37.0	20A2FRC1RA031	0.059
25	M25	3/4"	1"	15.0	3/4"	11.1	20.0	36.0	38.9	39.0	25A2FRC1RA032	0.112
32	M32	1"	1-1/4"	15.0	1"	17.0	26.3	36.0	38.9	41.0	32A2FRC1RA033	0.128
40	M40	1-1/4"	1-1/2"	15.0	1-1/4"	23.5	32.2	46.0	49.7	42.0	40A2FRC1RA034	0.168
50S	M50	1-1/2"	2"	15.0	1-1/2"	31.0	38.2	50.0	54.0	48.0	50SA2FRC1RA035	0.224
50	M50	2"	2-1/2"	15.0	2"	35.6	44.1	65.0	70.2	51.0	50A2FRC1RA036	0.231
63S	M63	2"	2-1/2"	15.0	2"	41.5	50.0	65.0	70.2	50.0	63SA2FRC1RA036	0.360
63	M63	2-1/2"	3"	15.0	2-1/2"	47.2	56.0	80.0	86.4	50.0	63A2FRC1RA037	0.344
75S	M75	2-1/2"	3"	15.0	2-1/2"	54.0	62.0	80.0	86.4	60.0	75SA2FRC1RA037	0.466
75	M75	3"	3-1/2"	15.0	3"	61.1	68.0	100.0	108.0	60.0	75A2FRC1RA038	0.395
90	M90	3"	3-1/2"	15.0	3"	61.6	80.0	100.0	108.0	79.0	90A2FRC1RA038	1.346

All dimensions in millimeters

NOTE: Other thread forms, materials and finishes are available. IEC Ex, ATEX & CSA hazardous area certification marking included as standard. Please consult CMP for any other requirements.

INSTALLATION INSTRUCTIONS FOR A2FRC CABLE GLAND WITH CONDUIT CONNECTOR

CABLE GLAND FOR USE WITH UNARMoured AND BRAID ARMoured CABLES HOUSED IN CONDUITS IN HAZARDOUS AREAS.

INCORPORATING EC DECLARATION OF CONFORMITY TO DIRECTIVE 94/9/EC

CABLE GLAND TYPE A2FRC

Cable Gland Selection Table



I, the undersigned, hereby declare that the equipment referred to herein conforms to 94/9/EC directive.

G. I. Mood

Dr Geof Mood - Technical Director - (Authorised Person)

Registered Office: Glasshouse Street • St. Peters • Newcastle upon Tyne • NE6 1BS
 Tel: +44 191 265 7411 • Fax: +44 191 265 0581

E-Mail: cmp@cmp-products.co.uk • Web: www.cmp-products.com

Company Number:

CE 0518

Notified Body: Sira Certification Service, Rake Lane, Chester CH4 9JN, England.



CMP PRODUCTS



INSTALLATION INSTRUCTIONS FOR CMP GLAND TYPE A2FRC

CABLE GLAND COMPONENTS

1. Entry Item
2. Seal
3. Skid Washer
4. Seal Nut
5. Conduit Coupling

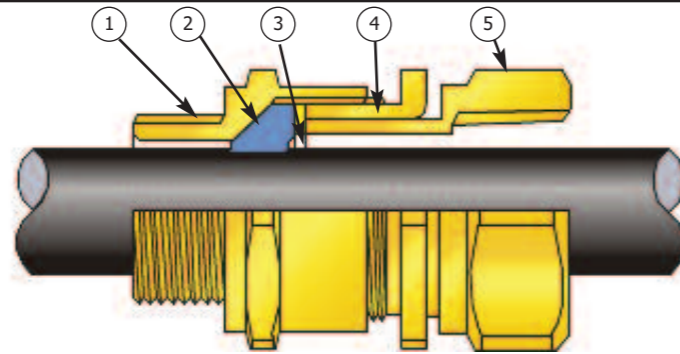

PLEASE READ ALL INSTRUCTIONS CAREFULLY BEFORE BEGINNING THE INSTALLATION

1. The A2FRC cable gland is suitable for all types of unarmoured cables, providing a flameproof seal on the outer sheath of the cable. It also has a rotating female-threaded coupling at the rear of the gland to allow the attachment of conduit.

This gland can also be used with braided cables where sealing is made on the cable outer sheath and the braid is earthed inside the equipment when this arrangement is allowed by the prevailing installation code of practice.

2. There is no need to dismantle the cable gland prior to installation. Simply slacken the Seal Nut (4) to relax the seal (2).

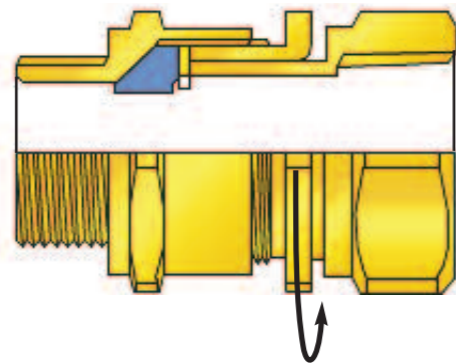

3. Fit the gland into the equipment and fully tighten the Entry Item (1).

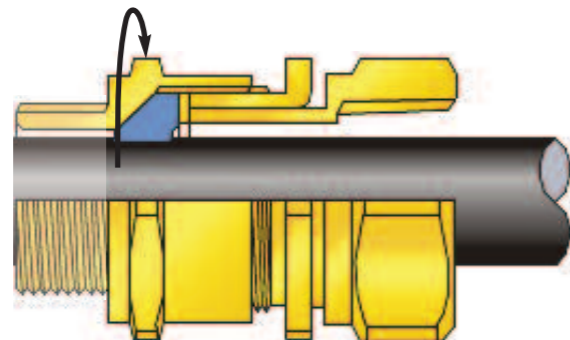

4. Determine the conductor length required to suit the installation and prepare the cable accordingly, removing part of the outer sheath where required to reveal the insulated conductors.

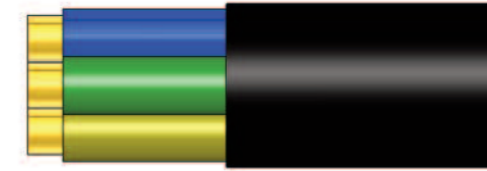

5. Pass the cable through the gland to the desired position, then tighten the seal nut by hand until resistance is felt (when the seal contacts the cable). Tighten with a spanner one further turn.

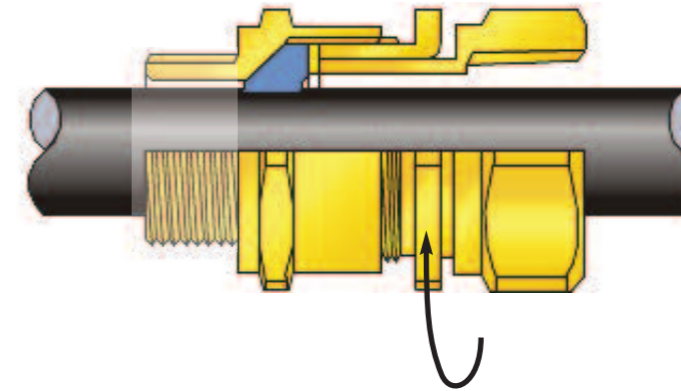

6. Attach the conduit to the Conduit Coupler (5) and fully tighten. Ensure that the Seal Nut (4) does not come loose during this process by holding it with a spanner.

